

Product Manual

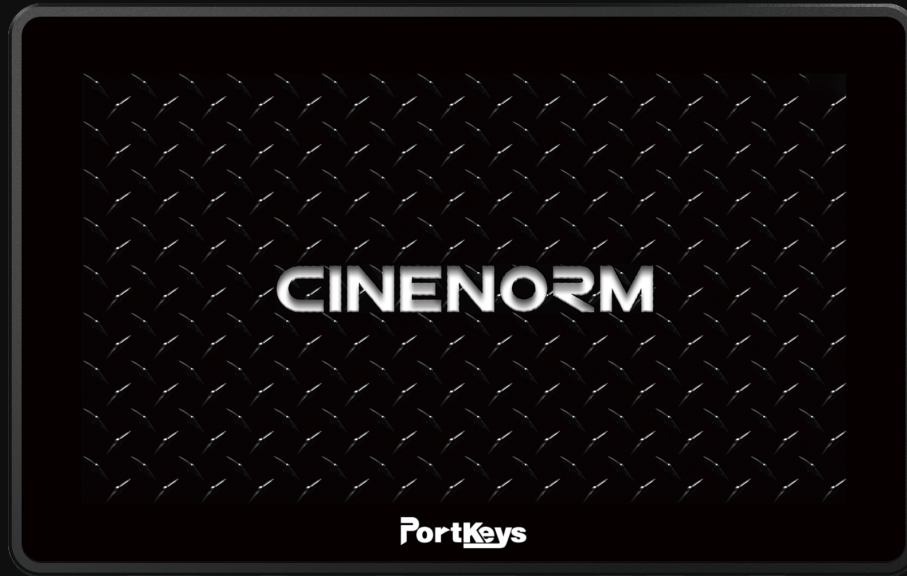

BM5 IV

Product Information

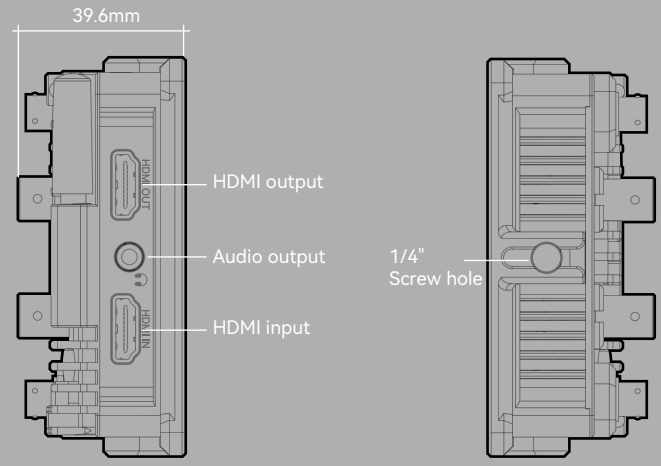
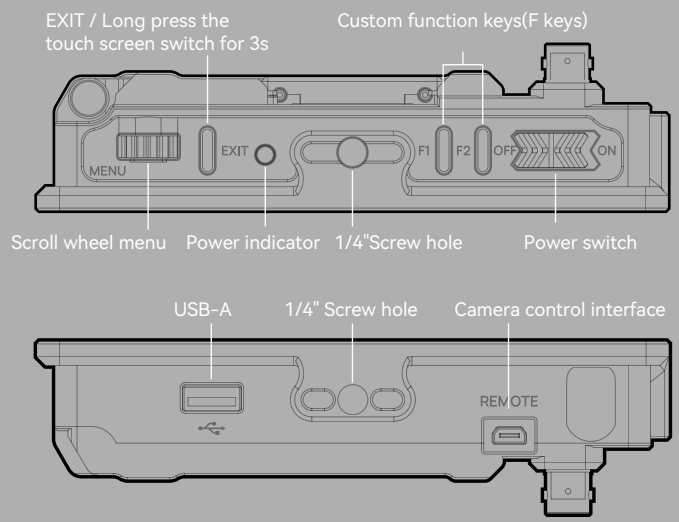
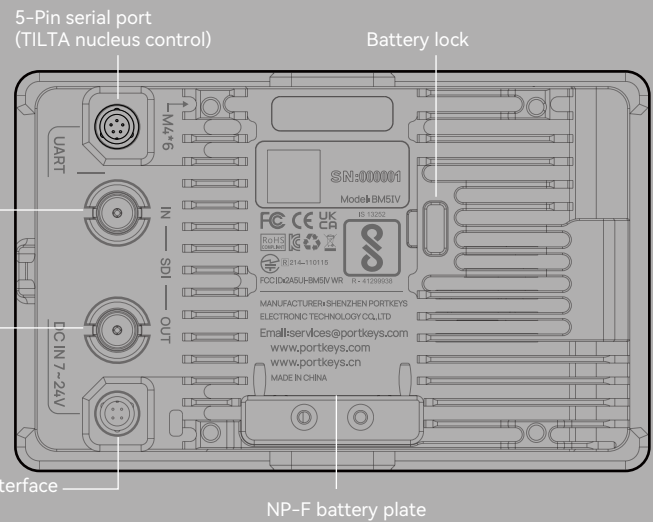

Basic Parameters

Screen Size:	5.5"
Dimension:	145.4×91.4×39.6mm
Viewing Angle:	178°H/178°V
Brightness:	2000nits
Resolution:	1920x1080
Contrast Ratio:	1000:1
Weight:	350g
Color Depth:	10bit (8+2FRC)
Material:	Aluminum alloy
Input Voltage:	7~24V
Maximum Power:	16W
Signal Input:	3G SDI、HDMI
Signal Output:	3G SDI、HDMI
Audio Output:	3.5mm Headphone jack
Menu Language:	简体中文/繁體中文/English/日本語/Русский/Français/español
Power Input:	4-Pin aviation connector
Signal Conversion:	HDMI/SDI Conversion
Camera Control Interface:	REMOTE
TILTA Nucleus Control Interface:	UART
Supported Battery Model:	SONY NP-F970/F960/F750/F550
USB-A:	Upgrade firmware / Load LUT
Fan:	Yes
Operating System:	CINENORM OS

Packing List

BM5IV Monitor X1
Customer feedback card X1
Safety box X1

D-Tap to 4-pin aviation connector power cable X1
Micro USB flash stick(manual, 3D LUTs, firmware inside) X1

Supported input/output resolution and frame rate

4K HDMI input/output signal

4096×2160p@23.97Hz,24Hz,25Hz,29.97Hz,30Hz,50Hz,59.94Hz,60Hz
3840×2160p@23.97Hz,24Hz,25Hz,29.97Hz,30Hz,50Hz,59.94Hz,60Hz

HDMI input/output signal

1920×1080p@23.97Hz,24Hz,25Hz,29.97Hz,30Hz,50Hz,59.94Hz,60Hz
1920×1080psf@23.97Hz,24Hz,25Hz,29.97Hz,30Hz
1920×1080i@50Hz,59.94Hz,60Hz
1280×720p@50Hz,59.94Hz,60Hz
720×576p&720×576i@50Hz
720×480p&720×480i@50Hz,59.94Hz,60Hz

SDI input/output signal

1920×1080p@50fps,59.94fps,60fps
1920×1080p@50Hz,59.94Hz,60Hz YUV422
1920×1080p@23.98Hz,24Hz,25Hz,29.94Hz,30Hz YUV444/YUV422
1920×1080psf@23.98Hz,24Hz,25Hz,29.97Hz,30Hz YUV444/YUV422
1920×1080i@50Hz,59.94Hz,60Hz YUV444/YUV422
1280×720p@50Hz,59.94Hz,60Hz YUV444/YUV422

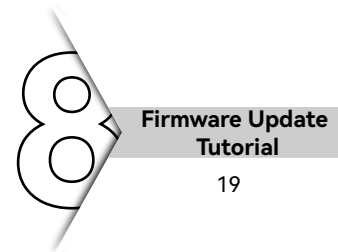
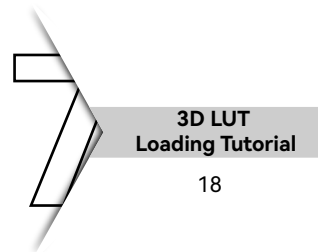
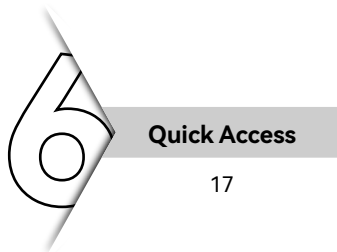
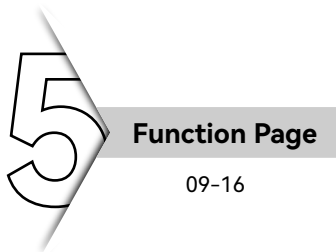
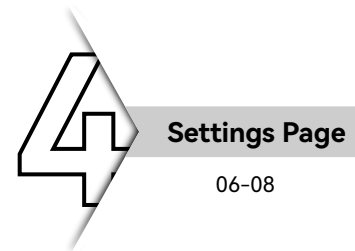
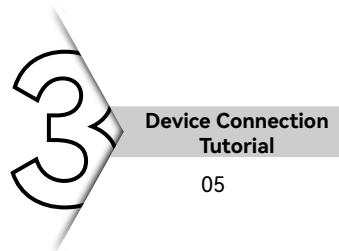
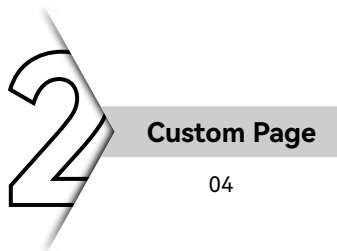
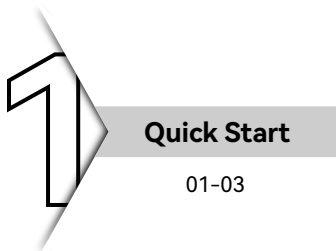



Initial Page

The background image is displayed after powering on the monitor. Tap the screen or press a button to bring up the main menu.

Operation Instructions:

- Touchscreen: tap, long press, or swipe (up, down, left, right).
- External Buttons: use the knob and other buttons (see "Product Info" for details).



Main Menu Operations

* Step

Tap the screen or press the knob to open the main menu.

Main Menu Overview:

- Backlight: slide to the bar adjust screen brightness.
- Fan: click "" and slide the bar to adjust fan speed.
- Volume: click "" and slide the bar to adjust volume.
- Device Connection: view connection status and modes.
- Monitor Settings: configure image, panel, signal input/output.
- Battery Icon: view current status.
- Add Functions: view and add functions.
- Help: show function icon names in the status bar.
- Functions: provide various tools for real-time monitoring, adjustment, and optimization of the captured image.



Monitor Status

* Step

Tap the battery icon in the top-right corner (not available on all pages).

Status Bar Overview:

- External Device Connection: view device connection status.
- Signal Input Settings: modify in "Monitor Settings > Input."
- Panel Calibration Info: view calibration status.
- Battery Voltage Info: click "" to switch power supply mode for accurate view.



Custom Page

* Step

Swipe down from the main menu to access the custom page.

Custom Page Overview:

- Page Name: click "👉" > "📄" to rename. Added Functions are displayed in the status bar.
- Manage Pages: rename, save as template, delete, or move pages when more than one page is created.
- Device connection mode is displayed on the bottom left. Click to enter the external device connection page.
- Signal input mode is displayed on the bottom right. Click to enter "System Settings > Input" page.
- Battery and Color Settings: displayed at the bottom.



Camera Control Connection Page

* Step

Click the connection icon "🔗" on the left of main menu page to enter.

Camera Control Page Overview:

- Wired Connection: connect the camera control cable to the "Camera Remote" port, then click "Connect" and select the camera brand. (Detailed tutorial on page 05)
- Motor: connect and use directly.



Monitor Settings Page

* Step

Click the settings icon "⚙️" on the left of main menu page to enter.

Monitor Settings Page Overview:

- Image Config: adjust display settings to optimize color and brightness.
- Panel Calibration: preset and custom color calibration.
- Input: select signal sources and configure camera LOG settings.
- Output: manage output signals.
- Image Flip: flip image horizontally or vertically.
- F Key Presets: assign monitor functions to physical F keys.
- System Config: adjust and manage basic monitor settings.
- User Profiles: store or import settings via USB.



Function Page

* Step

Click the function icon “” on the right of the main menu.



Function Page Overview:

- Exposure: adjust image brightness and identify overexposed areas.
- Waveform: analyze exposure and color distribution.
- Monitor: assist in composition and real-time image checks.
- Color Calibration: adjust and control image colors.
- Peaking: highlight focus areas for precise focusing.
- Multiview: display multiple image sources.
- Image Settings: adjust display settings to optimize color and brightness.
- Camera Control: control the camera directly from the monitor.



Adding Functions



* Step

Click the icon “” to open the function-adding page. Choose functions like “ Zebra” under “ Exposure” and adjust parameters. The zebra icon appears in the status bar when added. (Detailed tutorial on page 09)



F Key and Wheel Presets

* Step

Click “ Monitor Settings >  F Key Presets” to assign functions to F keys. Press the F key to activate. The wheel can also be preset for image or camera control functions.



1. Gesture Control

Swipe down on the main menu page to bring up the custom page.
Swipe left or right to switch between custom pages.



2. Custom Page Overview

1. Page Name: click "⊕ > □" to rename.
2. Manage Pages: rename, save as template, delete, or move pages when more than one page is created.
3. Device connection mode is displayed on the bottom left. Click to enter the external device connection page.
4. Signal input mode is displayed on the bottom right. Click to enter "System Settings > Input" page.
5. Battery and Color Settings: displayed at the bottom.



3. Adding Pages

Click "⊕" to add a new page with default settings. Adjust parameters based on shooting needs. Each page's settings are independent and tailored for different scenes or devices. Once preset, swipe left or right on the main menu to switch pages quickly.

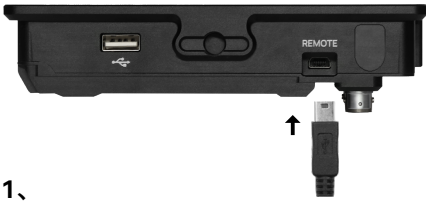

- 1、 Connect the Mini USB 10pin cable to the CAMERA REMOTE control interface at the bottom of the monitor, and connect the other end to the camera's control interface.



- 2、 On the main menu page, click the external device connection icon "🔒", select "🔒Wired (Camera Control)" and click "Connect."



- 3、 Once recognized, select the camera brand to complete the connection.



Image Config Page

Adjust display settings to optimize color and brightness.

* Step

Click the settings icon “⚙️” on the left side of the main menu, then select Image Settings to enter.

- Backlight: adjust the backlight brightness.
Range: 1~10
- Contrast: adjust the contrast between dark and light areas.
Range: 0~100
- Chroma: control the intensity of colors.
Range: 0~100
- Sharpness: adjust the image sharpness.
Range: 0~10
- Tint: adjust the overall color tone.
Range: 0~100
- Color Temperature: control the warmth or coolness of the display.
Range: 5500K, 6500K, 7500K, 9300K
Custom Range: red, green, blue (0~255)



Panel Calibration Page

Preset and custom color calibration.

* Step

On the main menu page, click the icon “⚙️” (left side) to enter Monitor Settings, then select Panel

- Bypass: disable all color calibration and processing, displaying the unadjusted raw signal.
- REC.709: standard color space for HD TV and online video, primarily used for broadcasting and HD content.
- P3-D65: wide color gamut space with D65 (6500K) white point for natural white balance and rich color reproduction.
- P3-DCI: the standard color space for digital cinema, following the Digital Cinema Initiative (DCI), suitable for filmmaking.
- User: custom color space calibrated to user preferences.



Input Page

Choose the correct signal source for the monitor to ensure the connected device uses the correct input method and adjust the camera's LOG mode as needed.

* Step

On the main menu page, click the icon “⚙️” (left side) to enter Monitor Settings, then select Input.

- Input Signal: manage the monitor's input signal settings.
- Input LOG: select the correct LOG mode based on the camera's settings. For example, if using a Sony camera with S-GAMUT color space and S-LOG curve, set the monitor to match these settings. The monitor's tools, such as False Color, will adjust based on the selected LOG signal. This allows you to monitor the image correctly across different LOG signals.



Output Page

Manage and adjust the monitor's output signals to better match different devices.

* Step

On the main menu page, click the icon "⚙️" to enter Monitor Settings, then select Output.

- Output Control: manage the monitor's output signal settings.
- LUT Output: apply specific LUT styles directly to the output image when exporting signals.
- 1080P Downscaling: process 1080p signals to lower resolution or through a single channel to optimize the signal path for specific device requirements.
- 3G Level A/B: transfer high-definition signals via the 3G-SDI interface. Level A transfers a single 1080p signal, while Level B splits the signal into two, enhancing compatibility with different devices.
- Display Sync: ensure that the image on the monitor is synchronized with the connected device, preventing delays or mismatches in the displayed image.



Image Flip Page

Adjust the display orientation of the image along the horizontal or vertical axes.

* Step

On the left side of the main menu, click the icon "⚙️" to enter Monitor Settings, then click Image Flip to enter.

- Horizontal Flip: reverse the image left to right, useful for mirrored setups.
- Vertical Flip: flip the image top to bottom, ideal for upside-down installations.



F Key Preset

Quickly enable or disable preset functions with a physical button for convenient operation.

* Step

On the left side of main menu page, click "⚙️" to enter monitor settings and click the "F Key Preset" to enter.

- Preset Operation: on the preset page, click the F key to set or change the preset function. A replaceable function page will appear; click the new function to complete the replacement.
- Scroll Wheel Preset: scroll wheel preset differs from F key preset. You can preset some image configuration and camera control functions. In the monitor's standby mode, scroll to adjust the preset functions.



System Configuration

Adjust and manage basic monitor settings.

* Step

On the main menu page, click the settings icon  and then "System Configuration" to access.

- OSD-Language: 简体中文/繁體中文/English/日本語/Русский/Français/español
- Opacity: adjust menu opacity for better viewing of screen content.
Adjustable Range: Off / Low / Medium / High
- System Reset: restore monitor to factory settings.
- Fan Adjustable Range: 1~10
- Camera recording on, sync fan at the lowest: automatically set the fan to the lowest speed when camera recording starts to reduce noise.
- Gesture Zooming: facilitate zooming in to view details.
- Volume Adjustable Range: 0~10
- SDI Tally: a signal indication system used in video production is often used in multi-camera shooting or live streaming
- Rec button position: adjust the position of the camera control record button.
Adjustable Range: left-bottom/ center-bottom/ right-bottom
- Firmware: view and manage the monitor's firmware version and update.



Firmware Page

For viewing and managing the monitor's firmware version and update.

* Step

On the left side of the main menu page, click the icon  to enter monitor setting and then click the "System Configuration> Firmware" to enter.

- Version info: check the current firmware version.
- Working Time: view the accumulated working time of the monitor.
- Software Update (USB): update firmware via USB to ensure the monitor runs the latest software version. (For detailed tutorial, please refer to page 19)



User Profile Page

Store or import monitor parameter files via an external USB to quickly switch monitors and avoid repetitive adjustments of various parameters.

* Step

On the left side of the main menu page, click the icon  to enter Monitor Settings and then click the "User Profile" to enter.

- Profile Name: display and change the current profile name
- Import: save current settings to external storage for easy restoration when changing monitors.
- Export: load previously saved settings from external storage to quickly restore personalized settings.

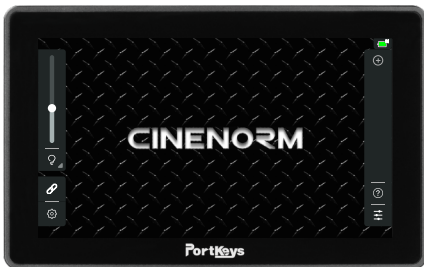

1、
On the main menu page, click the “☰” icon in the lower right to enter the function add page.



2、
Select the desired function categories.
For instance, click “Exposure > Zebra” to enter their adjustment page. The Zebra icon will appear in the function status bar on the right, indicating a successful addition.



3、
Click the icon “🗑️” above the parameters for the options of “🗑️ Delete”, “↔️ Position Adjustment”, “🔼 Return” and “🔄 Function Sync with Recording Key” to adjust the functions.



4、
Camera control function requires a connected camera to add.



5、
Click “❓” to view the nickname of the added function.



Zebra

Use zebra to customize the parts of overexposure and underexposure in the image.

Zebra and IRE Function: when the brightness of the image reaches the set threshold, zebra stripes will appear in those areas to indicate overexposure or underexposure.

-7 IRE: represents a very dark black, close to total black.

0 IRE: represents a completely black signal with no brightness info.

100 IRE: represents a fully white signal, reaching maximum brightness.

>100 IRE: indicates brightness levels that exceed the normal range, usually signifying overexposure.

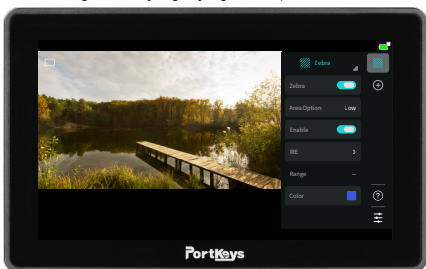

Quick Start Guide for Zebra Function

In the Monitor Functions menu, select Exposure > Zebra. After adding the function, enable zebra. Depending on your shooting goals, select whether zebra lines should display in the "Low," "Medium," or "High" exposure areas, ensuring critical areas are correctly marked.

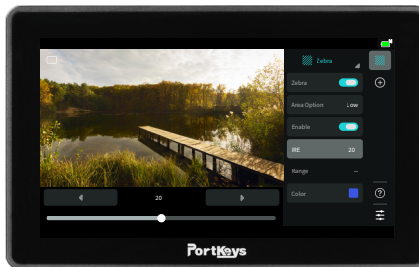

Example: when monitoring underexposed areas, select "Low" in the area options, adjust the IRE value to a suitable range, and if zebra stripes appear in the image, it means the area is too dark. Adjust your camera parameters (e.g., IRIS, SHUTTER speed, ISO) until the zebra stripes disappear or reduce, ensuring image detail is preserved.



Monitoring Overexposure: select "High" in the area options and set the IRE threshold between set the IRE threshold between 80 and 90 to prevent overexposure. Depending on your shooting needs, use zebra to monitor and mark exposure thresholds, adjusting the camera settings based on the feedback from the image.

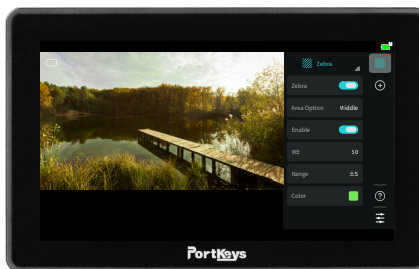

Monitoring Normal Exposure: in the area options, select "Medium" and set the IRE threshold between 40-70. A new Range option will appear, allowing more precise control of the zebra lines in the image to achieve optimal results.



False Color

Use specific colors to display the brightness level of the image.

Separates exposure areas by brightness value, with each color corresponding to a specific brightness range, allowing users to quickly identify overexposed, underexposed, and normally exposed areas.

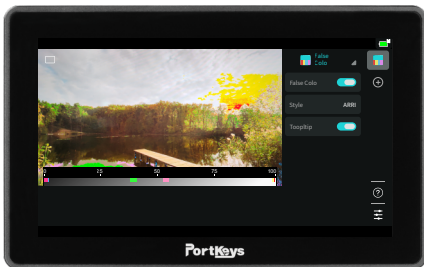

ARRI False Color: False color is widely used in scenarios requiring high dynamic range and precise exposure, like films and advertisements. It allows for a quick evaluation of brightness distribution, ensuring accurate exposure in key areas.

Green: normal light, usually referring to 18% medium grey.
 Yellow & Red: highlight areas. Yellow warns overbrightness; red signifies severe overexposure.

Blue: dark areas. Dark blue indicates areas close to or already underexposure.

Pink: skin tone exposure, assisting in proper exposure when shooting people.

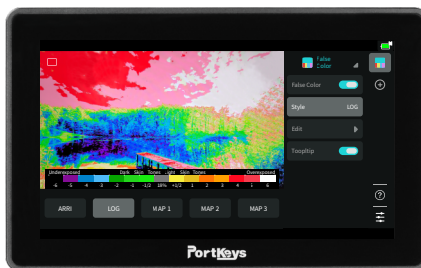

LOG False Color: designed for LOG gamma curves, this mode is often used to enhance dynamic range and retain more highlight and shadow details. Compared to standard false color, LOG false color provides more detailed exposure zones and finer exposure info, making it suitable for scenes that require precise brightness control.

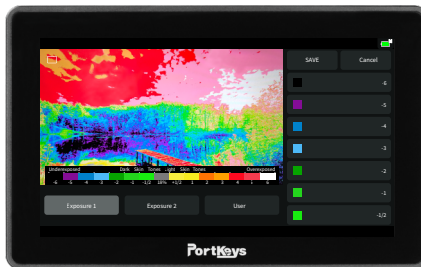

LOG Mode Recognition: the monitor can recognize the camera model and LOG curve type from the input signal. Based on the specific characteristics of the LOG curve, such as S-LOG, C-LOG, or V-LOG, the monitor adjusts the false color display accordingly. LOG false color maps different brightness and color ranges depending on the LOG curve, and users can also customize the color response in each exposure zone.



MAP 1: based on shooting needs, users can customize the false color settings, defining underexposure, normal exposure, and overexposure zones with different colors. Up to 15 zones and colors can be added.

False color settings can be customized for MAP 1, MAP 2, and MAP 3.



Peaking

Use the specific color to mark the focus position.

By analyzing the image captured by the camera, the peaking function compares each pixel's brightness or color with surrounding pixels. Once a high-contrast area is detected, peaking highlights those regions with bright colors, helping the user quickly identify the focus area.



In Monitor Functions > Focus > Peaking, after activating peaking, the image will be highlighted to show focus areas. Choose a highlight color suitable for the current shooting environment. Adjust the sensitivity to increase or decrease the highlighted area, then adjust the focus in real-time by moving the focus ring until the desired focus area is clearly marked.



Portrait Photography: when shooting portraits, peaking can be used to confirm the sharpness of the subject's eyes. By adjusting the focus ring, ensure the high-brightness mark on the eyes remains stable, indicating that the focus is accurately on the eyes.



Video Shooting: in video mode, peaking can be assigned to an F key for quick on/off control. During shooting, especially with focus pulling or fast transitions, peaking helps maintain sharp focus.

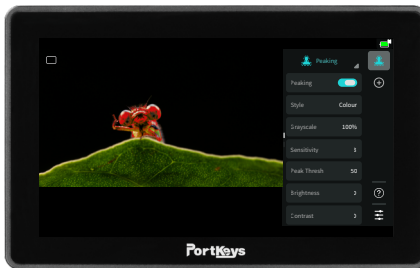

Macro Photography: when shooting small objects, peaking can help you pinpoint precise focus areas. Adjust the highlighted mark to target fine details, such as the stamen of a flower or the eyes of an insect.



Waveform(All)

Simultaneous display brightness, color, audio, and the image's oscillograms.

Load LUT: /

Options: /



RGB Waveform

Display three RGB colors of the image in dot plot distribution.

Opacity: Off/25%/50%/75%

Load LUT: / Full Screen: /

Position: / / / / / / /



Luma Histogram

Use a block plot distribution to display the brightness levels.

Opacity: Off/25%/50%/75%

Load LUT: / Full Screen: /

Position: / / / / / / /



Luma Waveform

Use dot plot distribution to display the brightness level.

Opacity: Off/25%/50%/75%

Load LUT: / Full Screen: /

Position: / / / / / / /



Vector Scope

Can be used with color cards as camera color calibration.

Opacity: Off/25%/50%/75%

Load LUT: / Full Screen: /

Position: / / / / / / /



RGB Histogram

Display three RGB colors of the image in block plot distribution.

Opacity: Off/25%/50%/75%

Load LUT: / Full Screen: /

Position: / / / / / / /

Separate Display: /



Audio Meters

Monitor volume levels.

Audio Channel: 2 Channel/8 Channel

Opacity: Off/25%/50%/75%

L/R Swap: Enable only in dual-channel mode

Position:



Image Overlay

Overlay semi-transparent JPG images in video.

(requires a USB stick)



Guides

Used for composition and masking.

Options: 80%/90%/1:1/16:9/9:16/15:9/4:3/1.5:1/1.85:1/2:1/2.35:1/2.39:1/User

Opacity: Off/Low/Middle/High

H/V: adjustable only in custom settings

Mark: Color:



Input

Input Signal.

Signal Input: HDMI/SDI



Image Capture

Capture a single frame image from a video and

store it as a JPG on a USB stick.

(requires a USB stick)



Grids

9 types of grid composition lines.

Regions: 1~9

Color:



Cross Hair

Cross mark in the center of the image.

X Offset: 0%~100%

Y Offset: 0%~100%

Color: / / / /



Check Field

Four solid color screens of red, green, blue, and white.

Color: / / / /



Anamorphic

Anamorphic De-squeeze.

Aspect: 1.33X/1.42X/1.50X/1.60X/1.66X/1.80X/
1.85X/2.00X/2.35X/User

Full: /



Rectangle Crop

Arbitrarily crop rectangular images for full-screen display.

Resize: adjust the cropping frame's position, width, and height horizontally and vertically.



Time Code

Display the time code of the HDMI and SDI videos.

Position: / / / / / / /

Color: / / /



Turn Off Screen

Enter standby mode, press any physical keys to wake up.

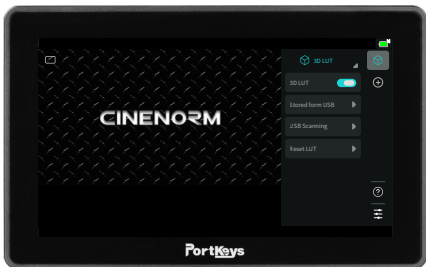

3D LUT

Screen color calibration LUT and styling LUT.

User Storage: LUT files stored on the monitor.
 USB Scanning: import LUTs from a USB stick into the monitor, accessible from User Storage.
 Revert the image to the state before LUT application. (For detailed steps, see page 18.)

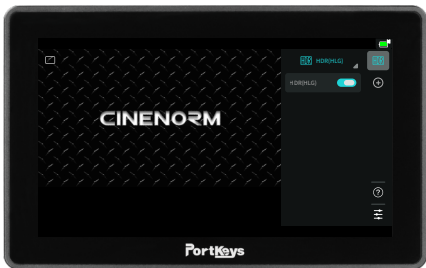

HDR(HLG)

HDR displays more shadow and highlight details.



PBP

Display two images simultaneously in both horizontal and vertical orientations.

Audio Out: A/B Set: A/B
 R90°: / Mirror: Off/H/V/ALL
 Input: HDMI/SDI



PIP

Dual video, simultaneously displaying two video screens of different sizes.

Audio Out: A/B Set: A/B
 Mirror: Off/H/V/ALL
 Input: HDMI/SDI
 PIP Position: / / /



H2V Crop

Display one horizontal image and crop another vertical image.

Mirror: Off/H/V/ALL
 Input: HDMI/SDI
 X Start: Adjust vertical crop in horizontal direction.



Camera Control

Camera Control Quick Save to F Key: hold to save camera control functions to F keys. For example, after selecting the shutter function, hold down external button F1-2 and wait for the countdown to finish to complete the save.



Switch Between Large and Small Screens

During operation, an icon “Zoom In” or “Zoom Out” appears in the upper left or right corner of the screen, allowing you to adjust the size of the image displayed.



Tool Switch Bind to Record Button

See Operation Instructions on page 10. After binding the record button, when recording starts, the monitor function will be enabled. (If a function does not support the current operation, a yellow exclamation mark will appear on the function icon.)

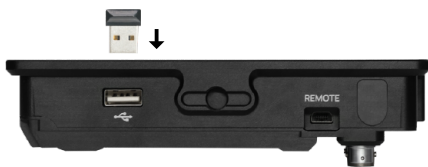

1、
Insert a USB stick containing the update file into the monitor's USB-A port.

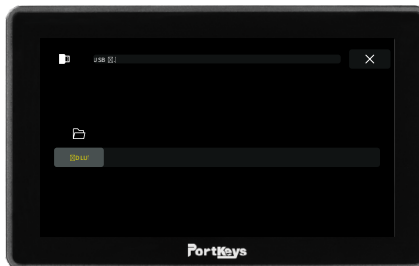

3、
Click the "3D LUT" folder, open the 3D LUT folder to access to LUT files.

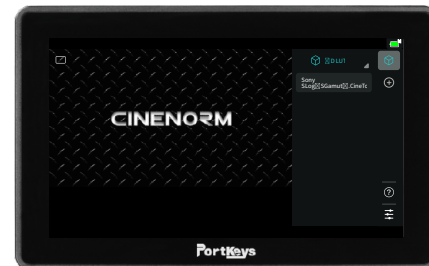

5、
In 3D LUT > User Storage, view the imported LUT files (LUT files can be repeatedly stored on the monitor).



2、
In Functions > Color Grading > 3D LUT > USB Search, click to search for LUT files stored on the USB stick.

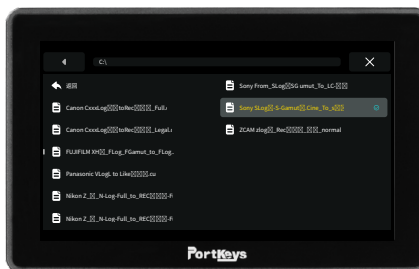

4、
Double-click the LUT file you want to store. Wait for the progress bar to complete, and the check mark "✔" will appear, indicating successful import.



6、
Click on the LUT file to "Apply LUT" or "Delete LUT".



1、

Download the corresponding firmware update package from the official website (portkeys.com), extract the main firmware update file, and transfer it to the root directory of the USB stick.



2、

Insert the USB stick containing the firmware update into the monitor's USB-A port.



3、

Go to Monitor Settings > System Configuration > Firmware > USB Software Update: click Yes to begin the firmware update.



4、

Select "Yes".



5、

The firmware update process takes several minutes. After completing, the monitor will black out and enter the configuration upgrade state. (Do not power off during the upgrading)



6、

Once the update is completed, check the firmware version in the firmware page to ensure it is up to date.